



INFSO-ICT-224557

BeAware

Boosting Energy Awareness
with Adaptive Real-time Environments

| | | | | |
|--------------------|----|---|----|-----|
| Instrument: | CA | STREP  | IP | NOE |
|--------------------|----|---|----|-----|

ICT - Information and Communication Technologies Theme

D4.5 Public Summary of Applications

Due date of deliverable (as in Annex 1): April 30th 2011

Actual submission date: May 26th 2011

Start date of project: May 1st 2008

Duration: 36 months

Organisation name of lead contractor for this deliverable: ENG

Revision: 1

| Project co-funded by the European Commission within the Seventh Framework Programme (2007-2013) | | |
|---|---|--|
| Dissemination Level | | |
| PU | Public |  |
| PP | Restricted to other programme participants (including the Commission Services) | |
| RE | Restricted to a group specified by the consortium (including the Commission Services) | |
| CO | Confidential, only for members of the consortium (including the Commission Services) | |



European Commission
Information Society and Media



| | |
|-----------------------------|--|
| Programme Name: | ICT |
| Project Number: | 224557 |
| Project Title: | Boosting Energy Awareness with Adaptive Real-time Environments |
| Partners: | COORDINATOR: AALTO (FI) CONTRACTORS: Aalto University AALTO BaseN Corporation, BaseN Interactive Institute II AB, II Engineering Ingegneria Informatica, ENG University of Padova, UNIPD Enel.si, ENELSI IES Solutions, IES Vattenfall Research and Development AB, VRD |
| Document Number: | |
| Work-Package: | WP4 |
| Deadline Date: | 30-April-2011 |
| Date of Delivery: | 26-May-2011 |
| Title of Document: | D4.5 Public Summary of Applications |
| Author(s): | Christoffer Björkskog (AALTO) |
| Responsible Partner: | AALTO |
| Reviewer: | Giulio Jacucci (AALTO) |
| History: | |
| Availability: | Public |



Table of Contents

| | |
|---|----|
| Executive Summary..... | 4 |
| 1. Introduction | 5 |
| 2. Energylife saving and awareness game | 5 |
| 3. Implementational building blocks | 6 |
| 3.1. Base Station and Smart Sensors | 6 |
| 3.2. Engaging Web Based User Interface..... | 7 |
| 4. Ambient Interface..... | 7 |
| 5. User Interface design update | 7 |
| 5.1. Carousel –homescreen..... | 8 |
| 5.2. House card..... | 8 |
| 5.3. Level info..... | 9 |
| 5.4. Energy Breakdown | 10 |
| 5.5. Ranking page | 11 |
| 6. The Ambient Interface..... | 12 |
| 6.1. Version 1..... | 12 |
| 6.2. Version 2..... | 12 |
| 7. References | 16 |



Executive Summary

We present Energy Life a system utilizing wireless sensors, mobile and ambient interfaces that turn energy consumers into active players. Energy Life participants play through different levels collecting scores in savings and through advice tip reading and quizzes. We describe principles, logic of the game, implementation and user interfaces providing rationale for design choices. Key principles embodied in Energy Life are: situated and combined feedback including knowledge and consumption information, intuitiveness and non-intrusiveness by utilizing an always at hand solution on a touch enabled smartphone and lighting as an ambient interface, sustained interaction and engagement by using a applied game that connects players within and between households.

The work is also publicly available in

Spagnolli et al. “Eco-Feedback on the Go: Motivating Energy Awareness”, IEEE Computer Volume 44 Issue 5, May 2011.

Björkskog et al. EnergyLife: Pervasive Energy Awareness for Households, in Proceedings of ACM UbiComp 2010.



1. Introduction

Aspects of energy saving in Human-Computer Interaction have interested firstly energy aware user interfaces on mobile and battery management. Just recently research on ubiquitous computing for energy management in the household has emerged. The work has followed three streams : 1) visualization of detailed data attained through pervasive sensing [3], 2) artistic visualization using novel interfaces [1] 3) theoretically informed implementation of feedback that address behavior change [4] . The problem of these three distinct streams is



Figure 1. Smart Sensor and Base Station.

that they have tackled separately three aspects that should be addressed at the same time respectively: detailed data sensing, engagement through novel user interfaces, and psychological and anthropological approaches to behavior change.

Our project aim at bridging these three streams by implementing an application that addresses detailed information provision, engagement through novel UI and theoretically informed feedback strategies.

2. Energylife saving and awareness game

Energy Life bases its persuasive potential on two pillars, awareness tips and consumption feedback. Awareness tips are meant to increase the users' knowledge of the consequences of their electricity consumption in general and of that of specific devices; consumption feedback makes the actual energy consumption visible to the users in terms of the updated distance from the selected saving goal. The two kinds of information together would help the users to monitor the quality of their conservation practices, and would enable them to know what to change in these practices in order better to achieve their goal. Both types of information are tailored to the actual consumption of individual devices and of the whole household.

In order to create a coherent, familiar, and attractive rationale for the use of EnergyLife, the pursuit of the saving goal follows a game-like rationale: awareness and consumption (saving) are expressed in scores; goals are divided into sub-goals connected to different levels of the game, so that the fulfillment of the objective on one level gives access to a higher level; higher levels have greater difficulty and richer functionalities; the saving activity can be discussed with other people participating in the same program; knowledge is tested through quiz and improved through contextualized tips, all of which contribute to increasing the awareness score.

This interface meets some of the basic usability requirements highlighted above; the system does not need the user to do anything special in order to access the feedback, since it can be



Figure 3. Ambient interface signals overall saving and status.

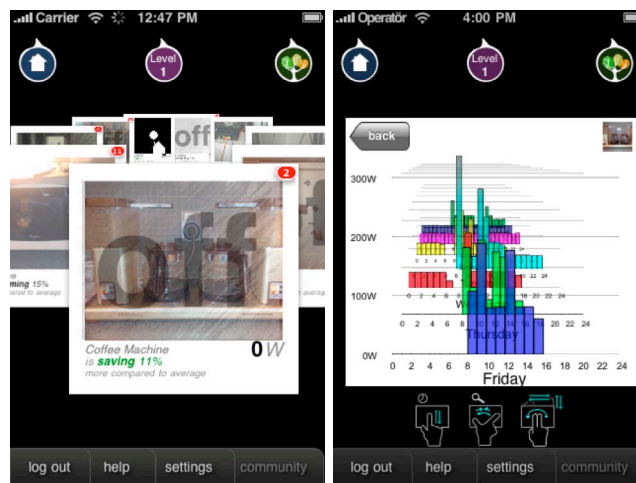

Figure 2. Interactive Web-based 3d UI Components

received on the same mobile device s/he uses for telephone calls; or, even s/he does not want to turn on his/her mobile, minimal feedback is provided anyway by the lights in the house, which dim when switched on when the goal is not met. The input system is also very easy, consisting of touching the screen in ways similar to the action one would perform on the actual object: rotations, pressures and ticks.

3. Implementational building blocks

3.1. Base Station and Smart Sensors

The heart of the system is the BeAware wireless sensor, which has been developed within the project. Compared to the commercially available alternatives, it is both more accurate and consumes less power [5]. It is connected between the wall socket and the appliances and takes its measurements from the line voltage and the current taken up by the appliance. It delivers data such as Apparent Power, Power Factor, Phase angle, Crest factor, Total Harmonic Distortion and Energy. The sensor is constructed in three parts: an analog



measurement connection, an analog to digital conversion and a micro controller running the sensor program and a radio communication part, which handles the wireless link.

All household data is processed in the BeAware base station, which handles the communication to all sensors and ambient interfaces and acts as a gateway to the Internet. Any linux/unix-based computer can act as a base station, but as it needs to be on (and preferably also online) all the time, a dedicated low-consumption machine is recommended. As part of the trials some different setups have been tested- current VIA Artigo runs a Debian Linux while consuming 15W. The system is also designed to be such that it can interface with 3rd party products as easily as possible. As example of this, we also uses Plugwise sensors as widely available alternative for BeAware sensors and SchellCount 1- and 3-phase meters as an alternative for main meter reading.

3.2. Engaging Web Based User Interface

The application client of Energylife is a standards-based mobile web application. Its main interface consists of a touch controlled 3-dimensional carousel [2]. Each card represents an electrical device whose consumption is monitored by sensors that, when flipped, reveals options to show device specific quiz, advice and consumption history.

4. Ambient Interface

The ambient interface (AI) consists of electronics that connect to the existing lighting of a household. It communicates wirelessly with the base station. When a light that is dedicated as an AI is switched on, it slowly dims up if the household is consuming too much electricity but immediately lights up if the household is saving energy. It can also, if it is switched on, alert by blinking when a certain condition has been met. With the current setup there is one AI in the household that reacts to the overall consumption. The next version will be several configurable AI's that respond to consumption regarding specific appliances, areas in the house or just the lighting.

5. User Interface design update

Based on user feedback from the first trial we designed an update to the user interface concept that is implemented for the second trial.



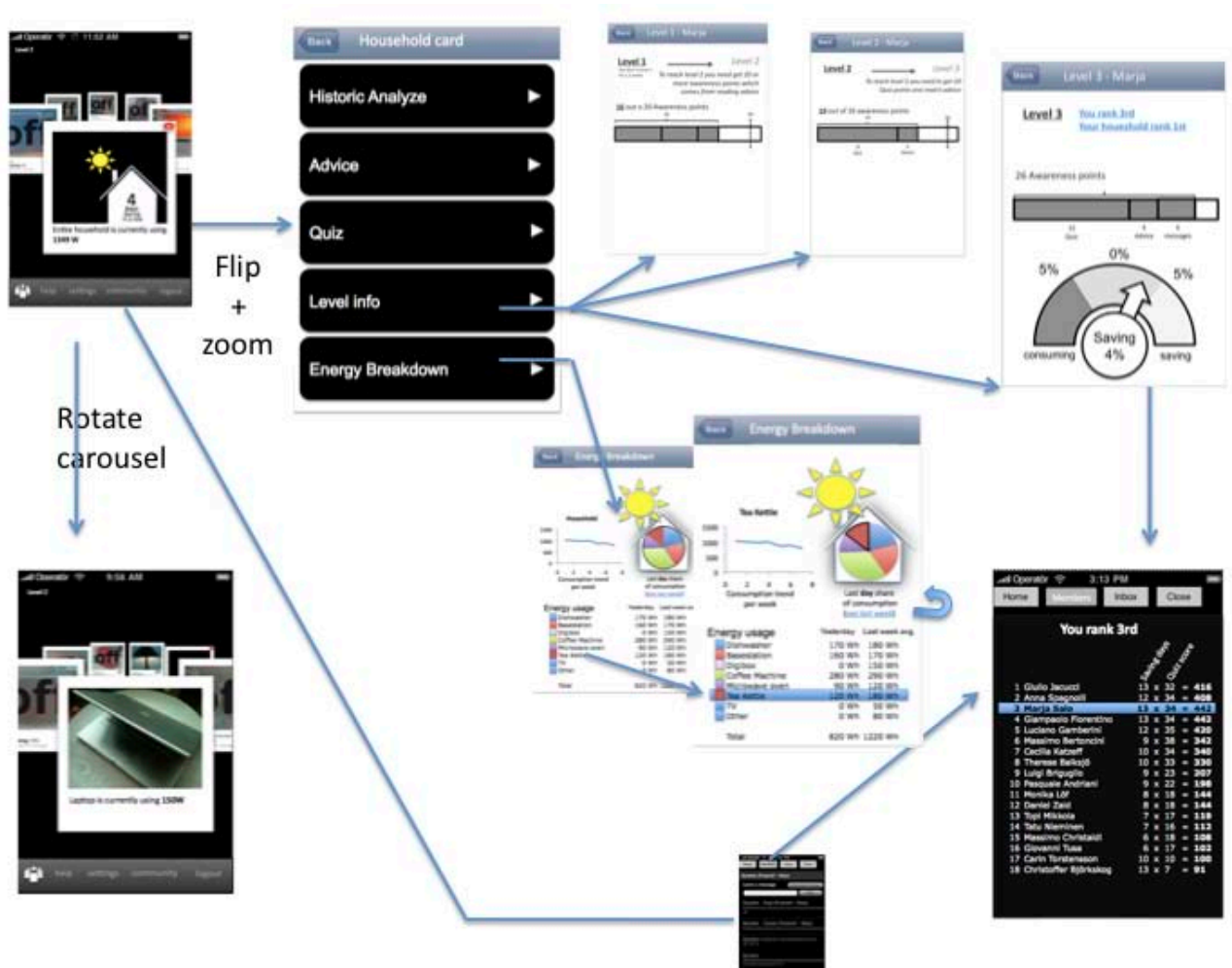

5.1. Carousel -homescreen

The changes to the home screen include removal of the three icons on the top of the screen to access three different pages. Now everything is integrated in the carousel and cards. When a card is flipped it is zoomed in to be represented in full screen mode complying with Apple guidelines to provide “screenfuls of content”.

5.2. House card

The house card displays cues about current level, scores and saving. By turning/flipping the card the user can access the house card menu items. Here Energy Breakdown and Level information is added.



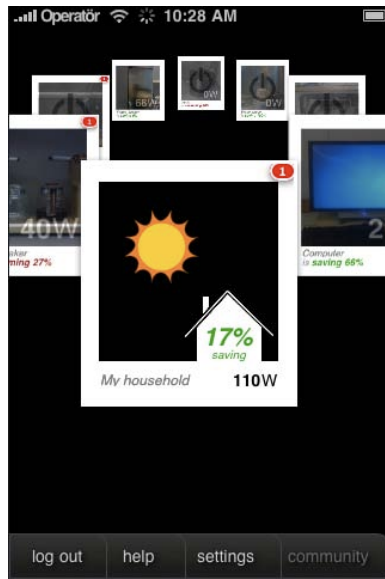

Simplification of the household card:

The sun shows the user that the household is saving, the cloud that the household is consuming, compared to the baseline. If the user wants to know more he/she can turn the card. The back of the house card looks like following.

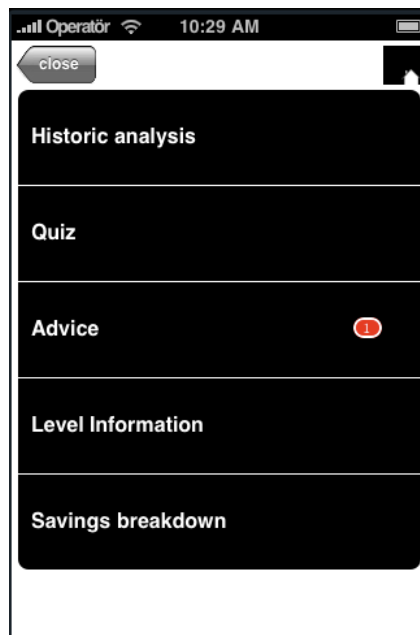

5.3. Level info

When you login for the first time, a help text would be displayed describing what the objectives of level 1 are, and this info is also available at the help menu. When you reach a new level, a dialog will appear describing the objective of that level.

The screens about the details on the level page are dependent on a decision on how the points and savings should be counted, so we need to agree on this first.



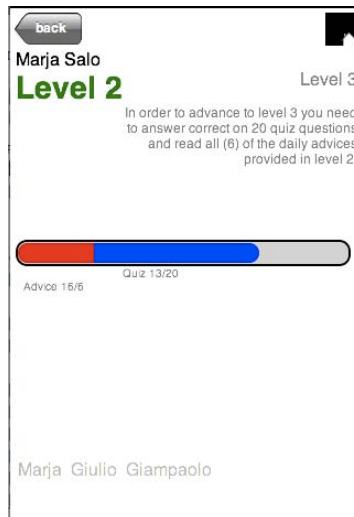

This user is at level 2

5.4. Energy Breakdown

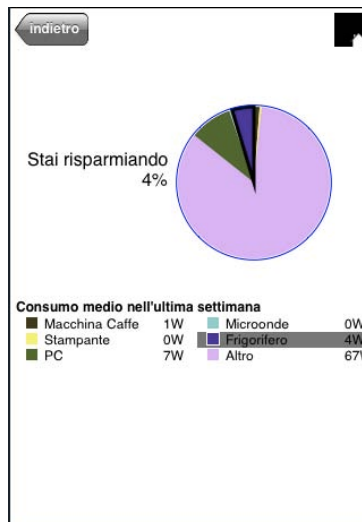

In the Energy Breakdown page we show: Last day share of consumption for each device and the total household.

When you click on a device text the corresponding piece in the chart will be highlighted.

5.5. Ranking page

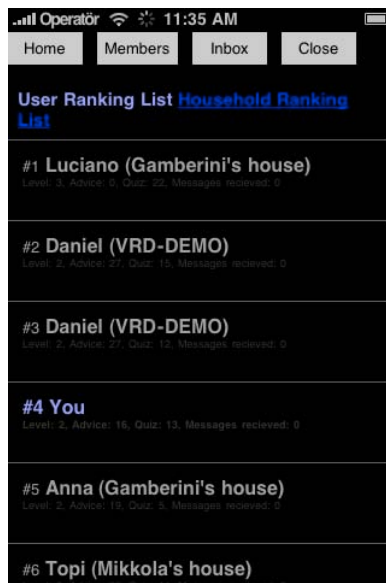

When users are in level 3, they get access to the community and can also see how well they compare to the other users. (the user in the screenshot is in level 2, for the screenshot, community was enabled for level 2)

From the level page, users can access the ranking page as well when they are in level 3.

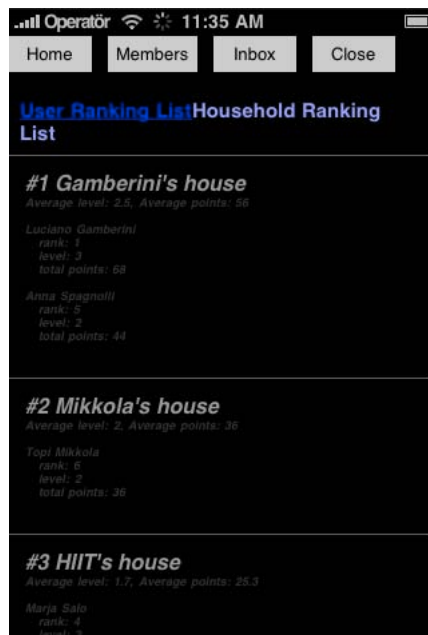

Users can see how well their household rank compared to other households as well and also see how well household members compare to each other.



6.The Ambient Interface

6.1. Version 1

The first versions has been finalized. It is now packaged as a modular component. And will be ready once the new wireless sensors with integrated AI support are built

6.2. Version 2

Concept and design of Second ambient interface has been produced.



The AI can hang as a lamp and display data on the surface underneath it

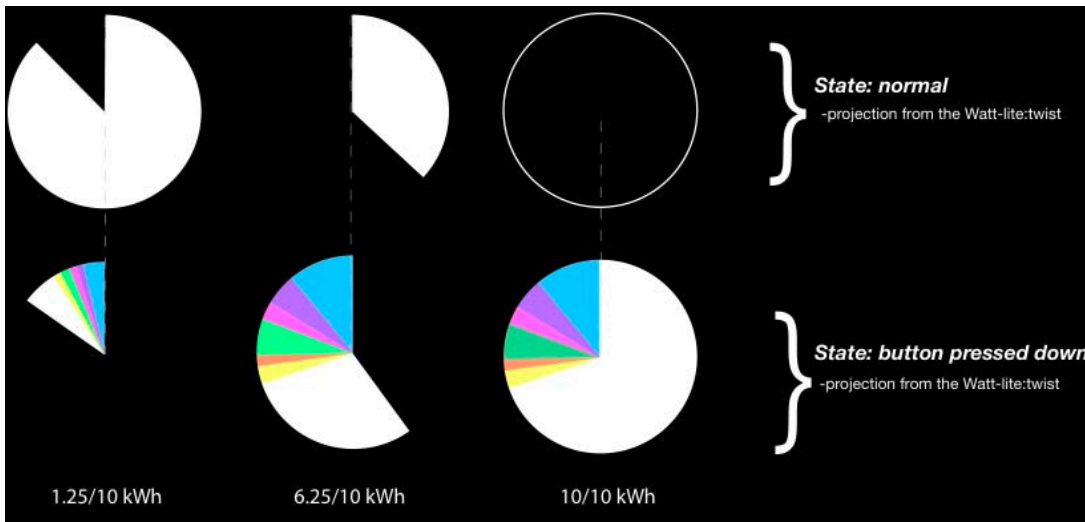

The data presented is a pie chart describing the certain electrical appliances consumption under a certain amount of “Watt”

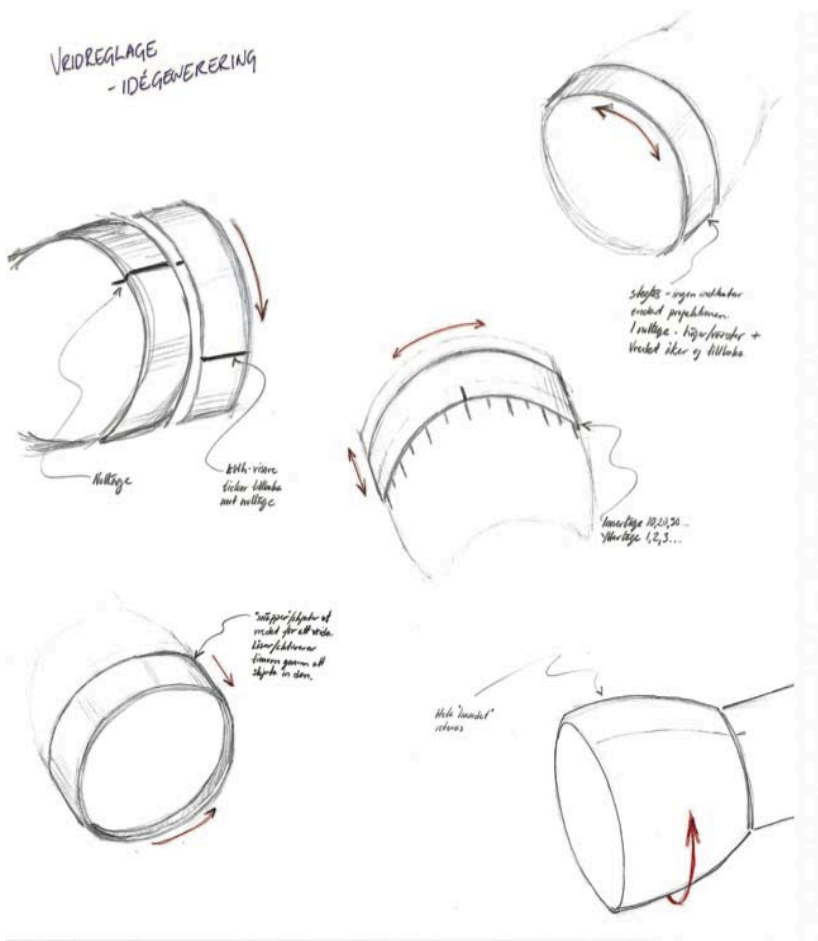

The interface is “wound up” in a similar way that an egg-timer is used. Except that electricity Watt are used instead of time seconds.





Different mockups of the second ambient interface

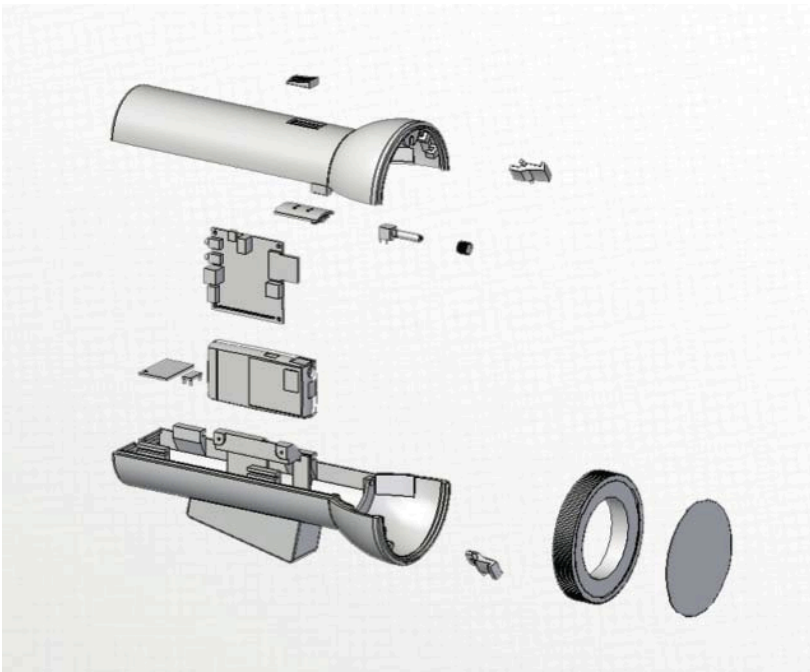

Exploded view of one of the mockups.



prototype projecting an image



The interface can also be used lying on a table.



7. References

1. Gustafsson, A., & Gyllenswärd, M. (2005). The Power Aware cord: energy awareness through ambient information display. In Ext. Abs. CHI '05, ACM Press, 1423-1426.
2. Jacucci G., Spagnolli A., Gamberini L., Chalambalakis A., Björksog C., Bertoncini M., Torstensson C., Monti P. (2009). Designing Effective feedback of Electricity Consumption for Mobile User Interfaces. *PsychNology Journal*, 7(3), 265 – 289.
3. Kim, Y., Schmid, T., Charbiwala, Z M., Srivastava, M. B. ViridiScope: design and implementation of a fine grained power monitoring system for homes, *UbiComp '09*, Pages 245-254.
4. Wood, G., & Newborough, M. (2003). Dynamic energy-consumption indicators for domestic appliances: environment, behavior and design. *Energy and Buildings*, 35 (8), 821-841.
5. Liikkanen, L., Nieminen, T. (2009). Comparison of End-User Electric Power Meters for Accuracy, *HIIT Technical Reports 2009–1*, ISBN 978-951-22-9489-3.
6. Spagnolli et al. “Eco-Feedback on the Go: Motivating Energy Awareness”, *IEEE Computer* Volume 44 Issue 5, May 2011.
7. Björkskog et al. *EnergyLife: Pervasive Energy Awareness for Households*, in *Proceedings of ACM UbiComp 2010*.

